



Automotive Equipment

HC4502 B HC3502 B

Electro-hydraulic two post lifts with base connection for low ceiling height

 Lifts

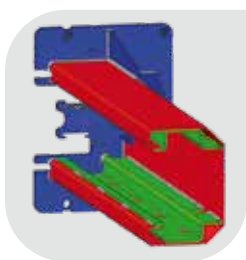

Internally reinforced column structure for little bending and internal cable guiding



Double threaded lifting pad to ensure excellent vertical adjustment (95÷180 mm)



HC4502 B - HC3502 B

Automotive Equipment



Realignment of the two carriages using metal cables that guarantee **excellent synchronisation**.



PROTECTIONS

Rubber door protections. **Toothed sector** arm rotation stop system.



ARMS

Four three-section asymmetrical arms.

Last section of arms very thin (30mm), for easy access to flat vehicles.

STANDARD ACCESSORIES

- Mechanical carriage support device on each column ensures optimum working safety.
- Two set of extension pads.

TECHNICAL DATA

Model	Teco HC4502 B	Teco HC3502 B
Lift capacity	4500 kg	3500 kg
Lifting time	40 s	
Three phase motor	400/230V - 3kW - 3Ph - 50/60Hz	
Single phase motor	230V - 3kW - 1Ph - 50/60Hz	
Max. lifting height	2003 mm	
Lift minimum height	115 mm	

OPTIONAL ACCESSORIES



8-4330021

Set of 4 extension for pads, H=35 mm



8-4330014

Set of 4 extension for pads, H=80 mm



8-4330015

Set of 4 extension for pads, H=140 mm



8-4330016

Set of 4 adapters for Mercedes Sprinter

See separate catalogue for further accessories.

DIMENSIONS

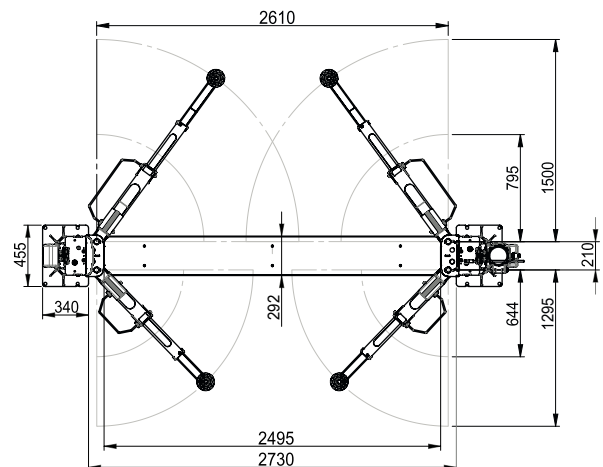
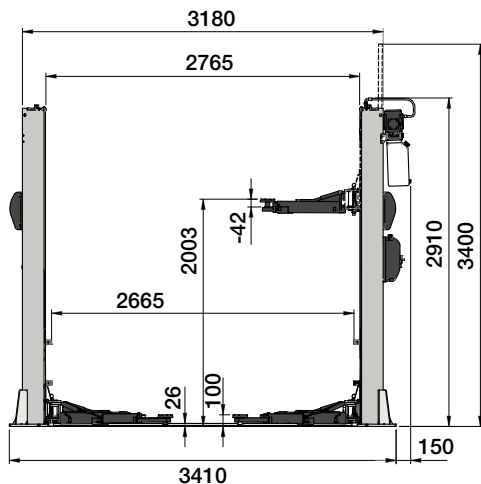

The manufacturer reserves the right to modify the features of its products at any time.

Cod. DPTC000523_06_2024



NEXION SPA - ITALY -
www.tecoautomotive.com - teco@teco.it

Designed in
ITALY

